

HDPE TO EXISTING PIPE CONNECTION

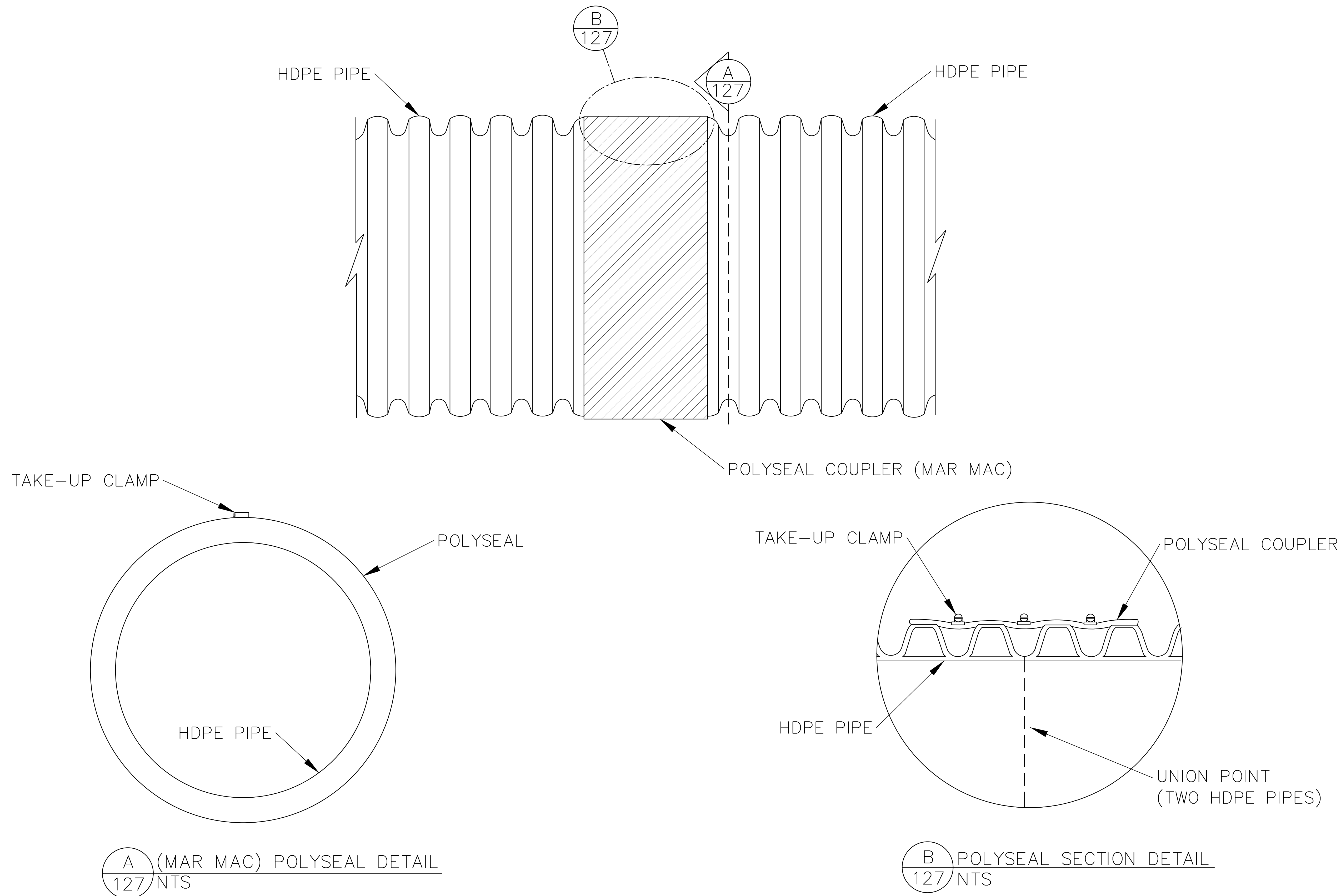

NOTES:

1. ALL PIPE SHALL BE INSTALLED IN ACCORDANCE WITH ASTM D2321 – STANDARD PRACTICE FOR UNDERGROUND INSTALLATION OF FLEXIBLE THERMOPLASTIC SEWER PIPE.
2. SEE MAR MAC INC., FOR SPECIFIC PRODUCT INFORMATION AND SELECTION
3. POLYSEAL IS A REGISTERED TRADEMARK OF MAR MAC PRODUCTS INC.